

MC-LM78xx series

76-81GHz FMCW Level Radar Operating Instructions



Table of Contents

1. Products introduction	2
1.1 Features	2
1.2 LM78xx series selection guide	3
2. Technical specifications	4
3. Install	5
4. Dimensions	7
5. Wiring	9
5.1 4-wire product	9
5.2 2-wire product	9
6. Local operation	10
6.1 Interface Description	10
6.2 Instructions for measurement interface	10
6.3 Instructions for Echo interface	11
6.4 Instructions for Setup interface	11
6.5 Menu options	14
6.5.1 Basic	14
6.5.2 Display	18
6.5.3 Diagnostics	20
6.5.4 Advanced	22
6.5.5 Information	31
6.6 Keyboard input method	32
7. Menu tree	34
7.1 First-level menu tree	34
7.2 Secondary menu tree-basic settings	35
7.3 Secondary menu tree-display	36
7.4 Secondary menu tree-diagnostics	36
7.5 Secondary menu tree-Advanced	37
7.6 Secondary menu tree-information	38
8. Problem Diagnosis	39
9. Software Version History	40
10. Error Code	41
11. Glossary	41

1. Products | introduction

1.1 Features

The LM78xx series is FMCW radar operating at 76-81 GHz, which has a maximum measuring range of 120m and a minimum blind zone of 8cm. It supports 4-wire and 2-wire applications. Higher operating frequency and shorter wavelength make it ideal for solid applications, including those with extreme dust and high temperature to + 200°C. The radar consists of an electronic circuit coupled to a lens antenna and flange for quick and easy positioning.

The main benefits of using 78 GHz over devices using lower frequency are:

- Based on the self-developed CMOS millimeter wave RF chip, a more compact RF architecture, a higher signal-to-noise ratio, and a smaller blind zone are realized.
- 5GHz working bandwidth means higher measurement resolution and accuracy.
- 3° antenna beam angle, so the interference in the environment has less impact on the instrument, and the installation is more convenient.
- Shorter wavelength yields good reflection properties on sloped solids, so aiming towards material angle of repose is usually not necessary.
- Support remote debugging and remote upgrading to reduce the cost of field personnel.

Communication and Programming

LM78XX supports 485 bus protocol (4-wire), serial-port (2-wire) protocol, and hart (2-wire) protocol. It is very easy to install and configure via an optional graphical local display interface on PC. Or you can modify the built-in parameters either locally via the push buttons. Or you can use cell phone to control LM78xx via Bluetooth.

1.2 LM78xx series selection guide

76-81GHz FMCW radar

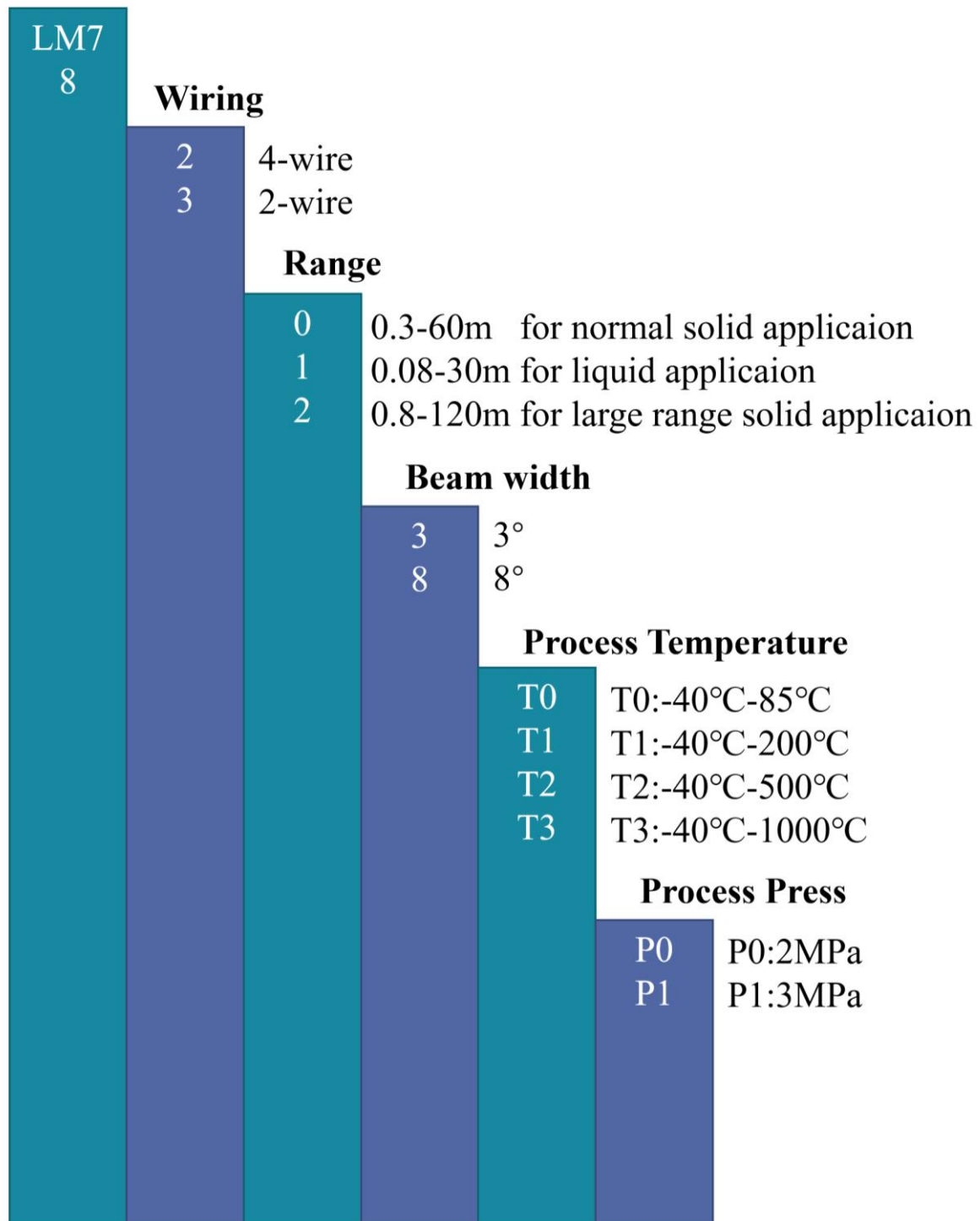

2. Technical specifications

Table1 LM78xx Technical Specifications

Frequency	76GHz ~ 81GHz, 5GHz FMCW bandwidth
Measuring range	LM78x0: 0.3 m ~ 60m LM78x1: 0.08m~30m LM78x2: 0.6m ~ 120m
Measurement accuracy	±1mm
Beam angle	3°/8°
Minimum measured dielectric constant	>=2
Power	15~28VDC
Communication	LM782x: MODBUS LM783x: HART/Series
Signal output	LM782x: 4 ~ 20mA or RS-485 LM783x: 4~20mA
Fault output	3.8mA, 4mA, 20mA, 21mA, hold
Field operation / programming	128 × 64 dot matrix display / 4 buttons PC software Bluetooth
humidity	≤95%RH
Enclosure	Aluminum alloy, stainless steel
Antenna type	Lens antenna/anti-corrosive antenna / flange isolated by quartz
Process temperature	T0:-40~85°C; T1:-40~200°C; T2:-40~500°C; T3:-40~1000°C
Process pressure	-0.1~2MPa
Product Size	Ø100*270mm
Cable entry	M20*1.5
Recommended cables	AWG18 or 0.75mm ²
Protection class	IP67
Explosion-proof grade	ExdiaIICT6
Installation method	Thread or flange
Weight	2.480Kg/2.995Kg
Packing box size	370*270*180mm

3. Install

The main concern of installation is to aim to the material surface under test and on the other hand to avoid false echoes. Typical scenes are list below for correct installation.

- Keep the antenna beam free of any interference such as ladders, pipes, steps, as shown in Fig.1.

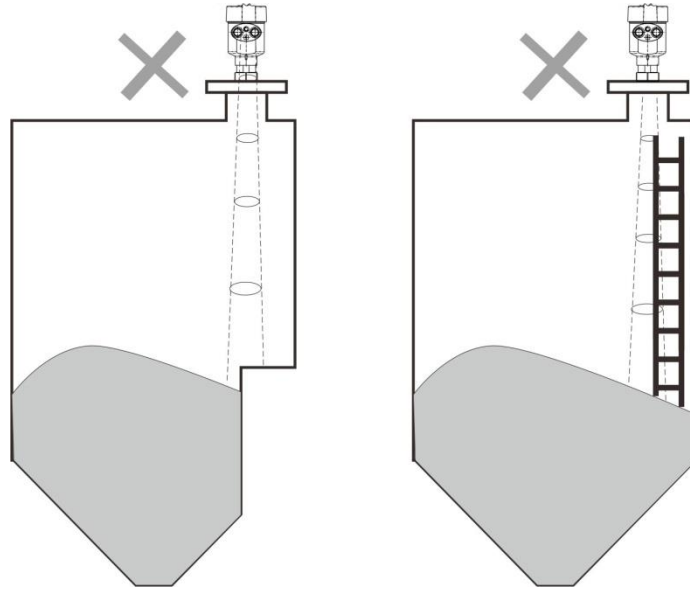

Fig.1 Example for avoiding false echo

- Avoid the contact between antenna beam and feeding flow, as shown in Fig.2.

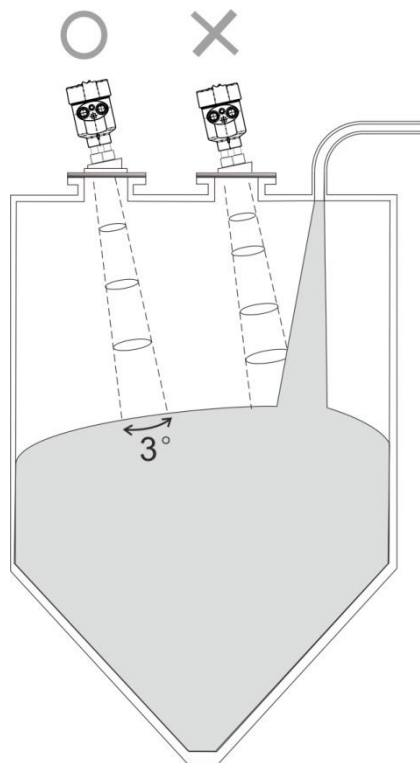

Fig.2 Example for avoiding false echoes

- At least 200mm away from the wall for avoiding false echo.

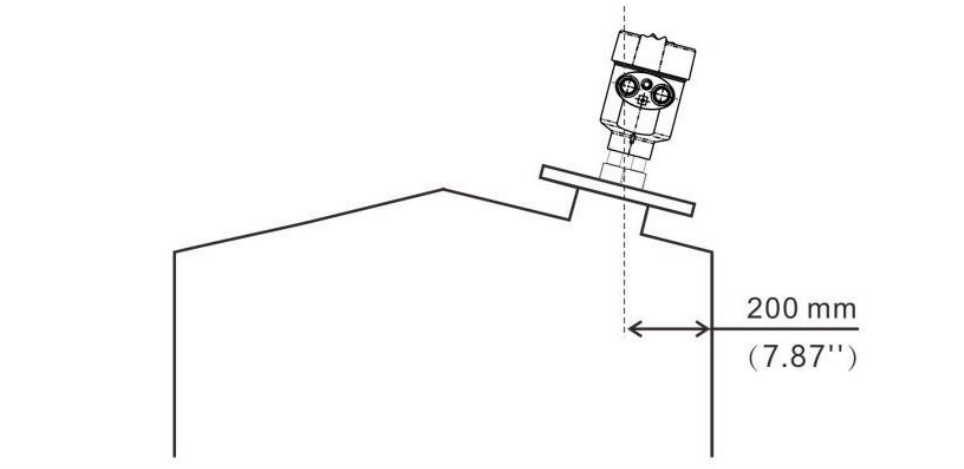

Fig.3 Example for avoiding false echo

- Aiming the antenna beam to the bottom of tapered vessel for avoiding false echo when the level is at the bottom of the tapered vessel.

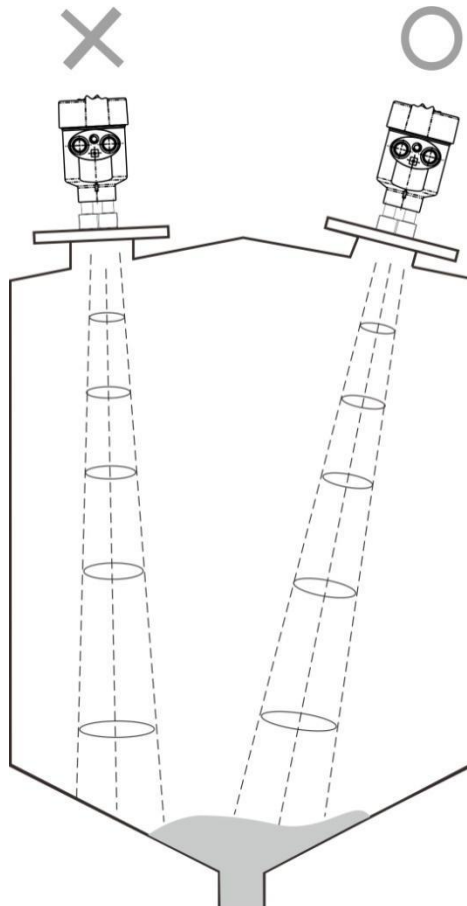
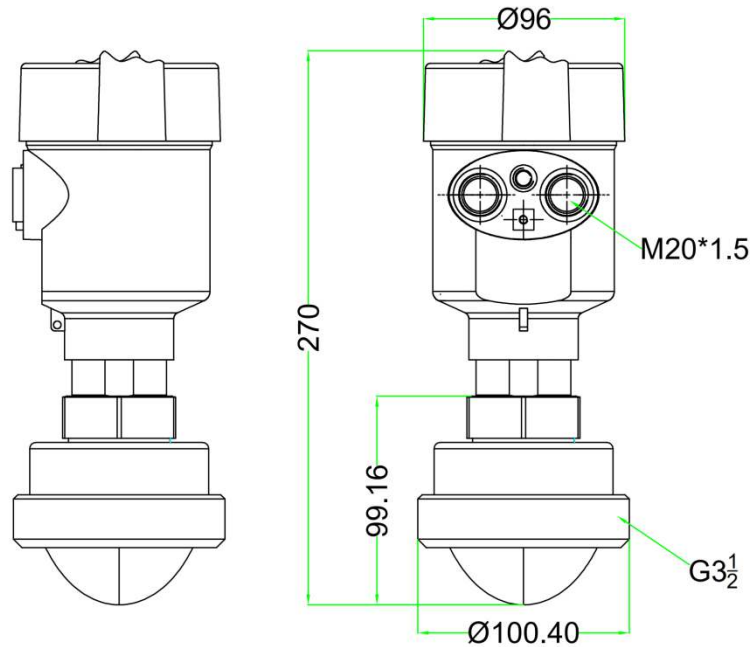

Fig.4 Example for avoiding false echo

4. Dimensions

LM78xx with 3° antenna beamwidth



LM78xx with 8° antenna beamwidth

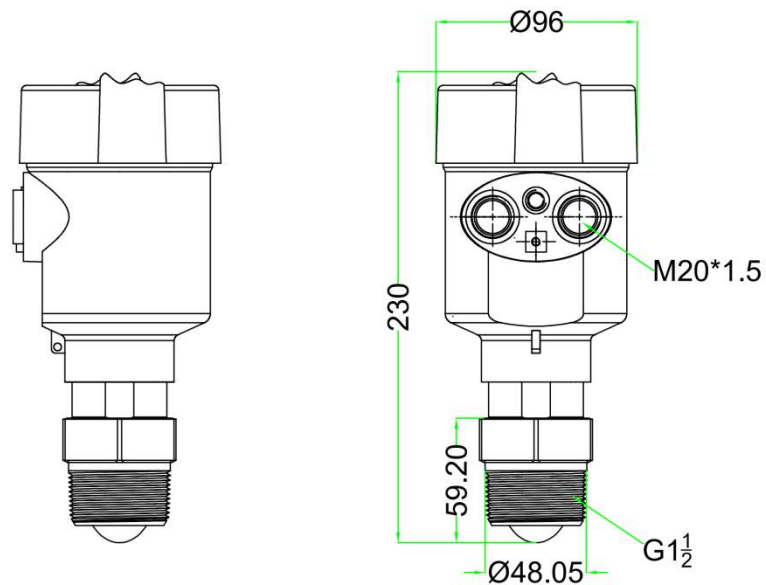
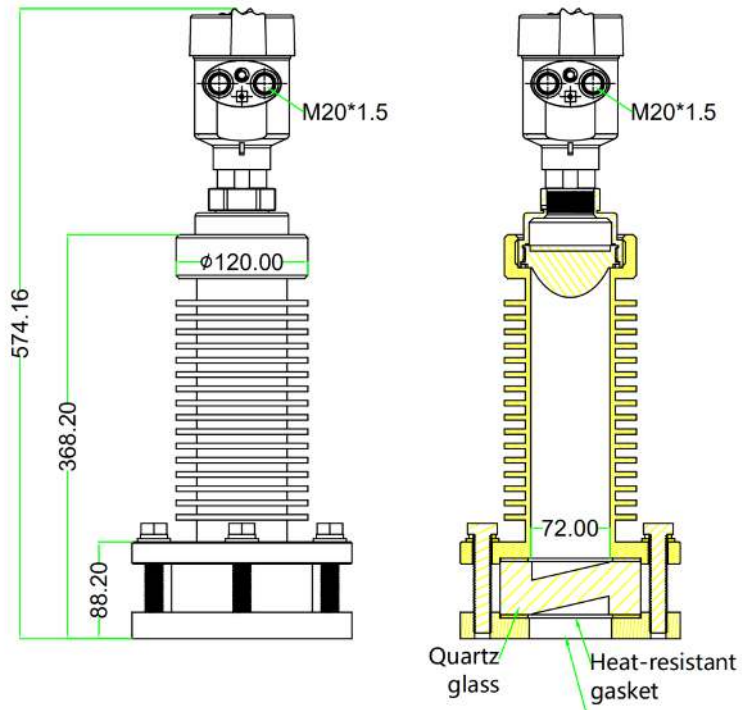

Fig.5 Dimensions for LM78xx series

LM78xx with 3° antenna beamwidth



LM78xx with 8° antenna beamwidth

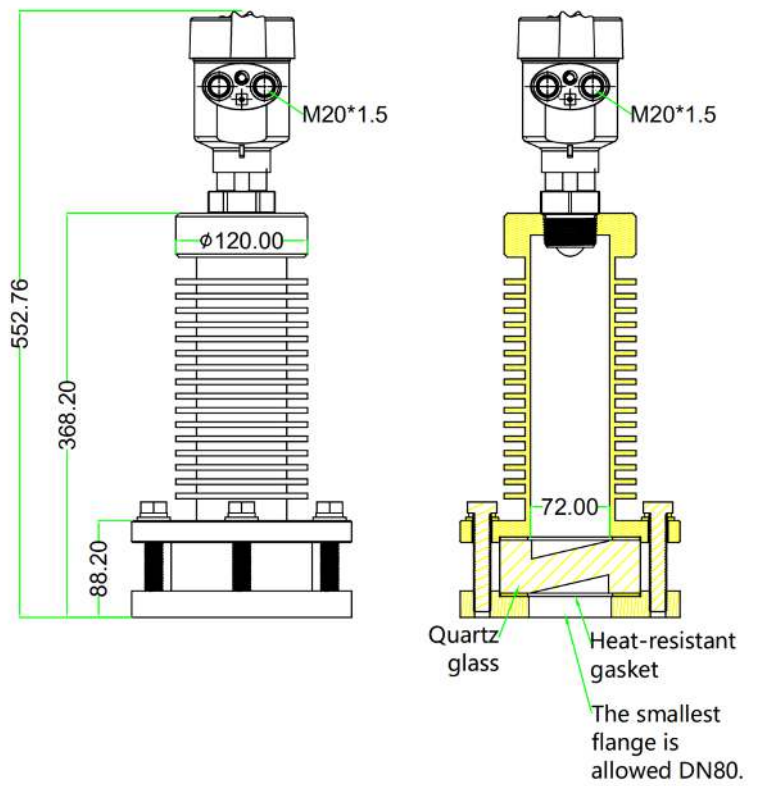

Fig.6 Diagram of high temperature resistant structure(for T2 and T3)

5. Wiring

5.1 4-wire product

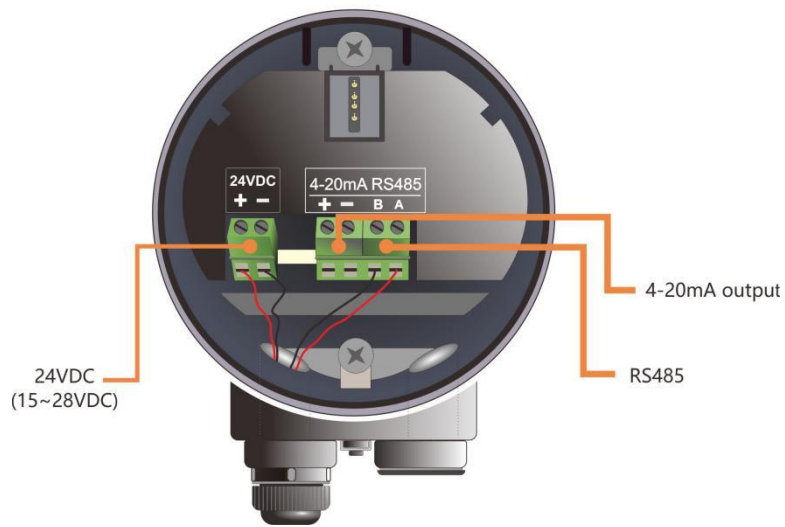

Fig.7 wiring diagram

5.2 2-wire product

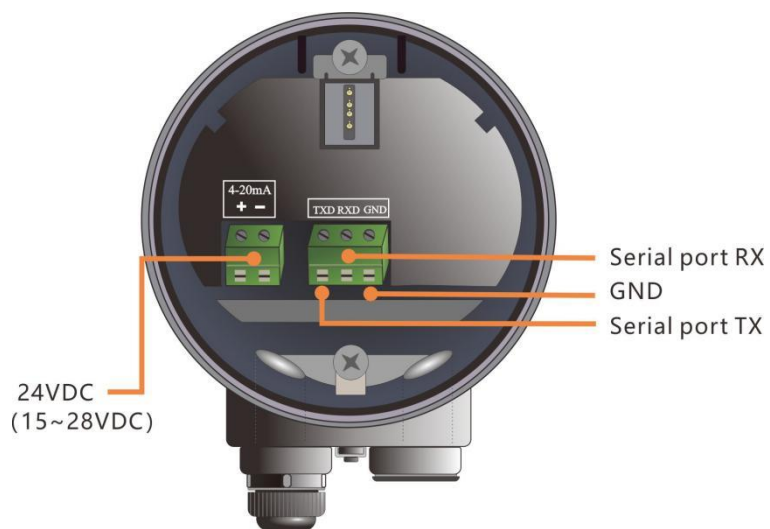

Fig.8 wiring diagram

6. Local operation

LM78xx carries out its level measurement tasks according to settings, which can be modified locally via the Local Display Module (LDM). LDM consists of an LCD with 4 push buttons.

6.1 Interface Description

LDM has 5 kinds of display interface:

[**Measurement Interface**]: Display system running status and current measurement result.

[**Echo Interface**]: Display the real-time measured echo curve and Time-Vary Threshold (TVT).

[**History Interface**]: Display historical measurement data recorded by the radar.

[**Setup Interface**]: Set various system parameters.

[**Input Interface**]: Take the task of input.

The functions of the 4 keys are different in different display interface.

6.2 Instructions for measurement interface

Measurement Interface is shown below:



Fig.9 Measurement Interface overview

Table2 keys function in Measurement Interface

Keyboard	Features
ESC	-Switch to echo interface
UP	-NULL
DN	-NULL
ENT	-Switch to Setup Interface

(1)It is the Real-Time measurement result, which is converted from the distance information of real-time measurement, corresponding to section 6.5.1.6.

(2) It is the **damping value** which is the smooth output of the real-time measurement through the damping filter. See section 6.5.1.5 for details.

- (3) It refers to the temperature of the signal processing board.
- (4) It refers to product model defined in section 1.2.
- (5) It refers to the heartbeat of system communication status. Once a second means that the device is working properly, otherwise the device is abnormal.
- (6)It refers to the system measurement unit, see section 6.4.2 for details.
- (7)It represents the ideal 4-20mA current output value, which is obtained according to the setting of **High/ Low Calibration Points** and **Current function**. See section 6.5.4 (6-8) for details.
- (8)It is the error code, refer to **Error Code** for specific meaning.

6.3 Instructions for Echo interface

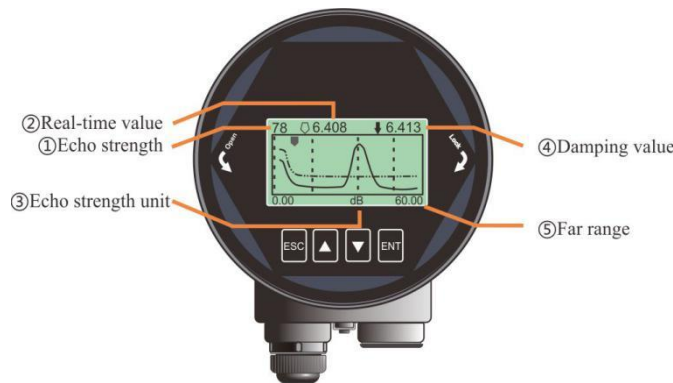

Fig.10 Echo Interface overview

Table3 keys function in Echo Interface

keyboard	Features
ESC	-Switch to Measurement Interface
UP	-No use
DN	-Show / hide TVT curve
ENT	-NULL

In **Measurement Interface**, press [ESC] key to enter the **Echo Interface**.

Specially in **Echo Interface**:

- It indicates the maximum echo intensity (not necessarily the echo selected by the algorithm) in the measurement range. For a metal plate, the echo intensity should be about 70dB. If the echo intensity is less than 30dB, it means that the reflection from the material under test is quite weak.
- Time Varying Threshold (TVT) and the real-time echo curve are represented in dash line and solid line respectively in Fig.10. Details for TVT refer to section 6.5.4.10-12.

6.4 Instructions for Setup interface

- Press [ENT] to switch from the **Measurement Interface** to the **Setup Interface**, as shown in the figure below:



Fig.11 Setup interface overview

Table4 keys function in Setup interface

keyboard	Features
ESC	-Switch to Measurement Interface/Exit
UP	-Move up
DN	-Move down
ENT	-Enter

6.4.1 [Basic]

[Basic] Menu contains the necessary functions for quick start of the level meter, as shown in the following table. The options list is shown in the table below:

Table5 Menu Item for Basic

Default position	Menu Item
●	Vessel type
	Material Type / Dielectric Constant
	Low calibration point
	High calibration point
	Damping
	Sensor mode

6.4.2 [Display]

[Display] Menu contains the necessary functions for setting the system unit. The option list is shown in the following table:

Table6 Menu Item for display

Default position	Parent menu item	Sub menu item
●	Sensor unit	<u>m</u>/cm/mm/ft/in
	Temperature unit	°C/K
	Language	Chinese/English

6.4.3 [Diagnostics]

[Diagnostics] Menu contains the necessary functions for historical record of the device. One can review the statistics of current and historical data.

Table7 Menu Item for Diagnostics

Default position	Menu Item
●	Historical maximum measurement
	Historical maximum temperature
	Historical Fill rate
	Historical Empty rate
	Echo curve
	Historical period
	Historical data

6.4.4 [Advanced]

[Advanced] contains various advanced settings for complicate environment or demand. The option list is shown in the following table:

Table8 Menu Item for Advanced

Default position	Menu Item
●	Near range
	Far Range
	Restore Factory
	Bus address
	Distance offset
	Current function
	4mA Setpoint
	20mA Setpoint
	Current simulation
	False Echo
	False echo range
	False echo mode
	Fill rate
	Empty rate
	Fail-safe current
	Fail-safe timer

6.4.5 [Information]

[Information] contains the options for inquiring the information about the device itself, as shown in the following table:

Table9 Menu Item for Information

Default position	Menu Item
●	Lcd version
	Device version

	Model
	S.N.
	Tag

6.5 Menu options

6.5.1 Basic

When the level meter is powered on, LCD enters measurement interface. Press the [ENT] key to enter [Basic] menu.

Note: Default settings indicated with an asterisk (*) unless explicitly stated.

6.5.1.1. [Vessel Type]



Fig.12 Vessel type overview

[Vessel Type] option has the impact on the radar algorithm based on the table below. Fill/Empty rate, damping time and tracking status are the main factors that would be changed automatically according to [Vessel Type].

Table10 details for [Vessel Type]

Parameter name	Vessel type		
	LM78x0	LM78x2	LM78x1
Large volume	Filling speed: 0.1m / min Damping time:60s		Filling speed: 0.1m / min Damping time:60s
Medium volume*	Filling speed: 1m / min Damping time:10s		Filling speed: 1m / min Damping time:10s
Fine volume	Filling speed: 10m / min Damping time: 0s		Filling speed: 10m / min Damping time: 0s
Demo	Damping time: 0s		Damping time: 0s

6.5.1.2. [Material Type/Dielectric Constant]



Fig.13 Material type overview

[Material Type] The setting is extremely important in complicate application such as low Dk liquid measurement. It should be selected according to the application.

Table11 Details for [Material type]

Solid		Liquid
Material type		Dielectric constant
Powder		> 10
Small solid		3-10
Large solid		<3

6.5.1.3. [Low calibration point]

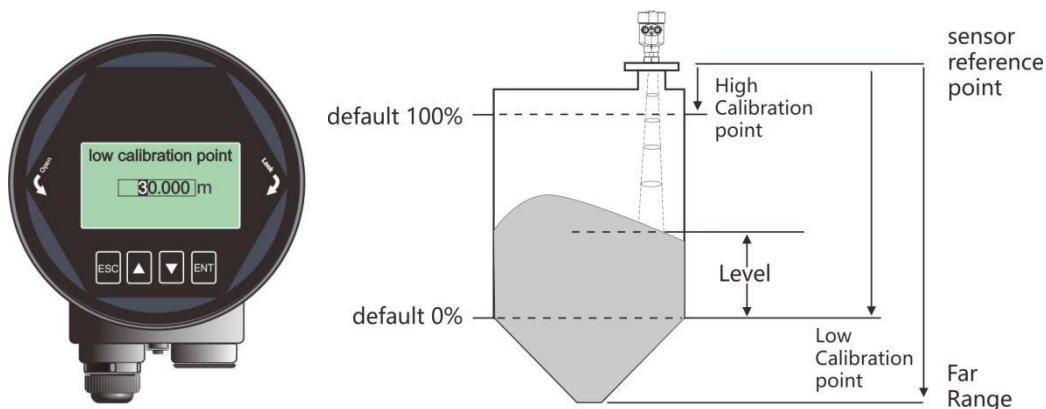

Fig.14 Low calibration point

[Low calibration point] (short for “low cal.”) relates to the range setting. It maps the corresponding relationship between the measured value and the current output (4-20mA) together with [High calibration point] (short for “high cal.”). Detailed input limitation for [low cal.] and the relationship between [low cal.] and [4ma/20ma setpoint] is summarized in following table.

Table12 Details for [Low calibration point]

	LM78x0	LM78x1	LM78x2
--	--------	--------	--------

Parameter name	Low calibration point		
Value Range (m)	1m ~ far range	1m ~ far range	1m ~ far range
Default value (m)	60	30	120
Related parameters	(1) If [low cal.] is less than ([high cal.] +0.1m), it will be set to ([high cal.] +0.1m). (2) In LEVEL mode, the 4mA setpoint will be automatically changed when changing Low calibration point . (3) In SPACE mode, the 20mA setpoint will be automatically changed when changing Low calibration point .		
Option meaning	(1) In LEVEL mode, it corresponds to [4ma setpoint]. (2) In SPACE mode, it corresponds to [20ma setpoint].		
Note	(1) No relation with far range. (2) Related to the Real-Time value and current output.		

6.5.1.4. [High calibration point]



Fig.15 High calibration point

[**High calibration point**] maps the corresponding relationship between the measured value and the current output (4-20mA) with [**low cal.**]. Detailed input limitation for [**high cal.**] and the relationship between [**high cal.**] and [4ma/20ma setpoint] is summarized in the following table:

Table13 Details for [High calibration point]

	LM78x0	LM78x1	LM78x2
Parameter name	High calibration point		
Value range (m)	0 ~ (low cal. -0.1m)	0 ~ (low cal. -0.1m)	0 ~ (low cal. -0.1m)
Default value (m)	0	0	0
Related parameters	(1) If [high cal.] is greater than ([low cal.] -0.1m), it will be set to ([low cal.] -0.1m). (2) In LEVEL mode, the 20mA setpoint will be automatically changed when changing High calibration point . (3) In SPACE mode, the 4mA setpoint will be automatically changed when changing High calibration point .		
Option meaning	(1) In LEVEL mode, it corresponds to [20ma setpoint]. (2) In SPACE mode, it corresponds to [4ma setpoint].		

Special matters

- (1) No relation with **near range**.
- (2) Impact on the **real-time value** and current output.

6.5.1.5. [Damping]

[Damping] smoothes out the response to a sudden change in level. In five time constants, the output rises exponentially: from 63% of the change in the first constant, to almost 100% at the end of the fifth time constant.

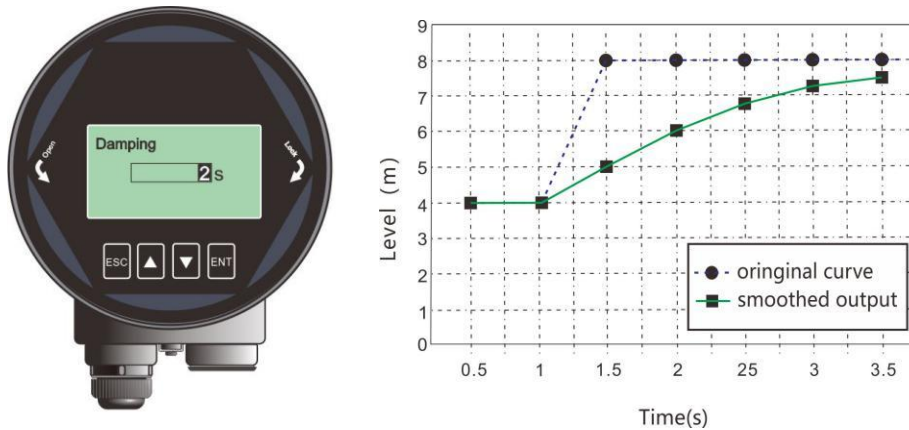

Fig.16 Damping

Table14 Details for [Damping]

	LM78X0	LM78X1	LM78X2
Parameter name	Damping		
Parameter range (s)	0~600		
Default (s)	60		
Related parameters	Null		
Option meaning	Smooth out the response to a sudden change in level.		
Special matters	Null		

6.5.1.6. [Sensor Mode]

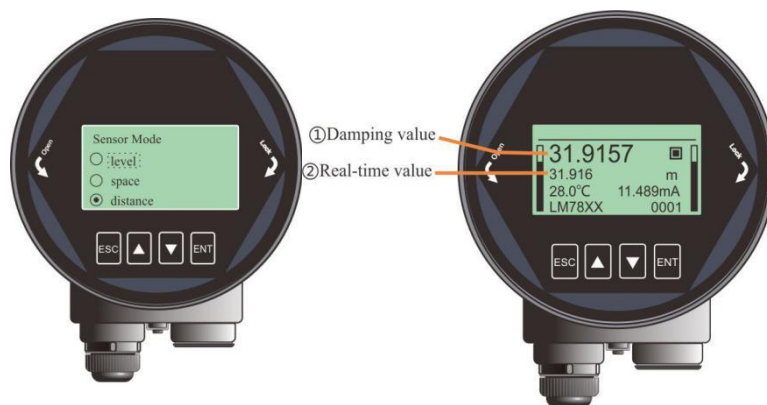

Fig.17 Sensor mode

[Sensor mode] decides the specific display form of the **real-time value** and **damping value**. There are three kinds of forms: LEVEL, SPACE and DISTANCE. Detailed definition and calculation method is shown in the table below:

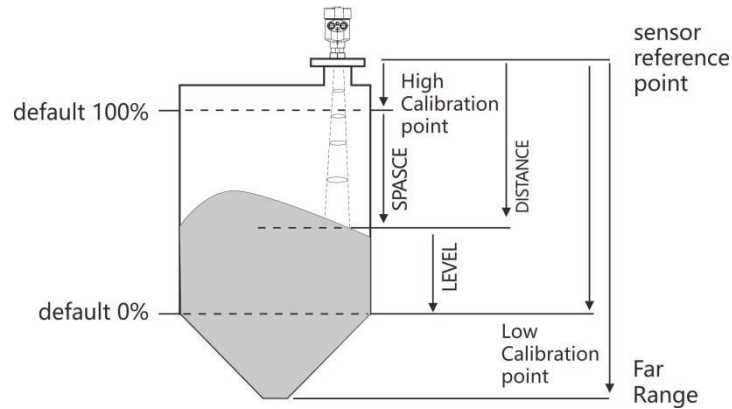

Fig.18 Definition for LEVEL, SPACE, DISTANCE

Table15 Details for [Sensor mode]

	LM78X0	LM78X1	LM78X2
Parameter name	Sensor mode		
Default	Distance		
Related parameters	Null		
Option meaning	Level: Distance from Low Calibration Point to material surface. Space: Distance from High Calibration Point to material surface. Distance: Distance from Sensor Reference Point to material surface.		
Special matters	(1)In Distance mode: real-time value = measured distance. (2)In Level mode: Real-time value = [low cal.]-measured distance. If the measured distance is greater than [low cal.], LEVEL=0. (3)In Space mode: Real-time value = measured distance-[high cal.]. If the measured distance is smaller than [high cal.], SPACE=0.		

6. 5. 2 Display

6.5.2.1. [Sensor unit]

[Sensor Unit] defines the unit of the **real-time value** and **damping value** shown in **Measurement Interface**.



Fig.19 Sensor unit

6.5.2.2. [Temperature unit]

[Temperature Unit] defines the unit of temperature shown **in Measurement Interface**.

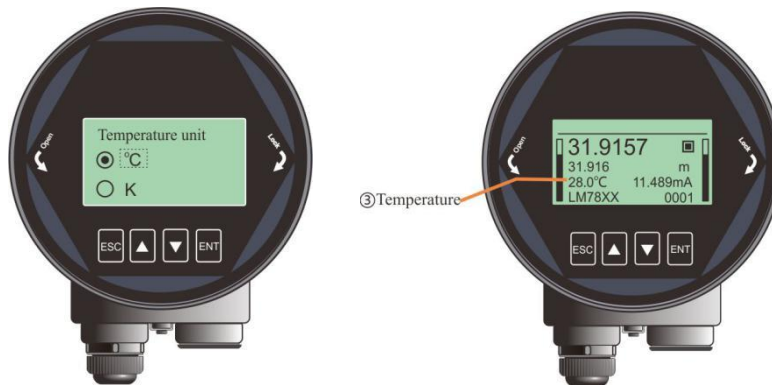

Fig.20 Temperature unit

6.5.2.3. [Language]

[Language] selects the system language to be used on LCD.



Fig.21 Language

6. 5. 3 Diagnostics

6.5.3.1. [History Maximum Measurement]

By pushing the [Read] button, [Historical Maximum Measurement] shows the statistical results of the measured maximum and minimum level since last [Clean]. [Clean] clears the statistical results and then the recording will be restarted.



Fig.22 History Maximum Measurement

6.5.3.2. [Historical Maximum Temperature]

[Historical Maximum Temperature] shows the statistical results of the MCU operating temperature since last [Clean].



Fig.23 History Maximum Temperature

6.5.3.3. [Historical Fill Rate]

[Historical Fill Rate] shows the statistical results of measured maximum and minimum fill rate of the material.



Fig.24 Historical Fill rate

6.5.3.4. [Historical Empty Rate]

[Historical Empty Rate] shows the statistical results of measured maximum and minimum filling rate of the material.



Fig.25 Historical Empty Rate

6.5.3.5. [Echo curve]

Refer to [Echo Interface].

6.5.3.6. [Historical period]

[Historical period] sets the time range of [Historical curve].



Fig.26 Historical period

Note: Only even number from 2 to 360 is accepted and the unit is hour.

6.5.3.7. [Historical data]

According to [Historical period], [Historical data] shows the historical trend of the measurement. The data on the right is newer. The number in the upper left corner shows the maximum peak in the curve and [Historical period] is shown in the upper right corner. Maximum statistical period is 360 hours, i.e. 15 days.



Fig.27 Historical data

6.5.4 Advanced

6.5.4.1. [Near range]

Only the Echoes between the ranges from **[near range]** to [Far range] would be considered and has the possibility to be chosen by the algorithm. And **[near range]** should not be set smaller than blind zone according to the corresponding modal, otherwise it may cause instability or wrong reading.



Fig.28 Near range

Table16 Details for **[near range]**

	LM78x0	LM78x1	LM78x2
Parameter name	near range		
Parameter range (m)	0~([far range]-0.1m)	0~([far range]-0.1m)	0~([far range]-0.1m)
Default value (m)	0	0	0
Related parameters	If [near range] is greater than (([far range]-0.1m), it will be set to ([far range]-0.1m).		

6.5.4.2. [Far range]

Only the Echoes between the ranges from [**near range**] to [**far range**] would be considered and has the possibility to be chosen by the algorithm.



Fig.29 Far range

Table17 Details for [**far range**]

	LM78x0 (solid)	LM78x1 (liquid)	LM78x2 (solid)
Parameter name	far Range		
Parameter range (m)	0.1~60	0.1~30	0.1~120
Default value (m)	60	30	120
Related parameters	(1) If [far range] is set smaller than ([near range] + 0.1m), it will be automatically set to ([near range] + 0.1m). (2) In DISTANCE mode, [4ma setpoint] is directly related to [far range].		

6.5.4.3. 【Factory reset】

It is used to restore the default factory settings of the level meter. The recovery time is about 15s to 20s. After that, LCD will jump to **Measurement Interface** automatically.



Fig.30 Factory reset

6.5.4.4. [Bus address]

[Bus Addresses] is used to assigning address for the instrument and guarantee multiple instruments

working properly on the bus. Set the bus address according to the corresponding protocol.



Fig.31 Bus address

Table18 Details for [Bus address]

	LM782x	LM783x
Parameter name	Bus address	Hart address
Parameter range	1-247	0-15
Defaults	1	0
Related parameters	Null	Null
Option meaning	Set the Modbus address.	Set the Hart short address.
Special matters	System will reboot after setting	System will reboot after setting. Output Current will be fixed at 4mA when non-zero valus.

6.5.4.5. [Distance Offset]

[Distance Offset] is used to compensate the shift of sensor reference point according to actual requirement. The default reference point is calibrated to the front end of the lens point “a”. If sensor reference point need to be set to point “b”, just input “h1”; or if it need to be set to point “c”, just input “-h2”.

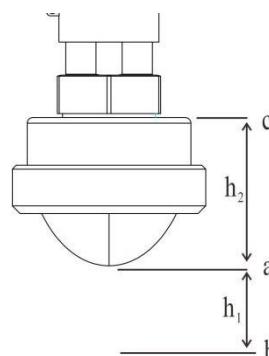

Fig.32 Distance Offset

Table19 Details for [Distance Offset]

	LM78X0	LM78X1	LM78X2
Parameter name	Distance offset		
Parameter range (m)	-(Selfoffset)~+10m		

Default value (m)	0
Related parameters	Null
Option meaning	Compensate the shift of the sensor reference point.
Special matters	Null

6.5.4.6. [Current function]

[Current function] decides real-time output loop current according to [4ma/20ma setpoint].



Fig.33 Current function

In the different options, 4ma (0%) and 20ma (100%) position is shown in the figure. Choose the option according actual need.

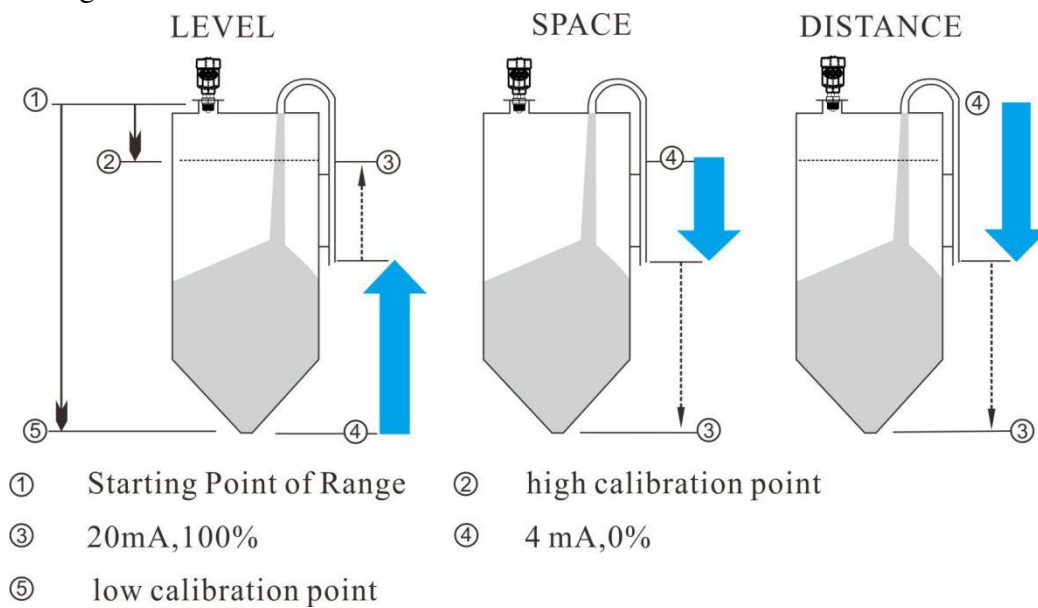

Fig.34 corresponding relationship between 4/20ma setpoint and low/high calibration point

Table20 Details for Current function

	LM78X0	LM78X1	LM78X2
Parameter name	Current function		
Defaults	Level		
Related parameters	Refer to Fig.34		
Option meaning	Decide real-time loop current according to [4ma/20ma setpoint].		
Special matters	The default 4ma and 20ma setpoint refer to the low/high calibration point or		

the option [4ma setpoint] and [20ma setpoint] set manually.

6.5.4.7. [4ma setpoint]

Set the 4ma setpoint (0% position) individually and thus the default corresponding relationship between 4ma and [low/high cal.] would be discarded as a result.



Fig.35 4ma setpoint

6.5.4.8. [20ma setpoint]

Set the 20ma setpoint (100% position) individually and thus the default corresponding relationship between 20ma and [low/high cal.] would be discarded as a result.



Fig.36 20ma setpoint

6.5.4.9. [Current simulation]

[Current simulation] is used to check the loop current output accuracy. The loop current will keep the value set by [Current simulation] for testing. Once you exit the interface shown in Fig.37, calibration is over and the loop current would be set according to [Current function], which means that the instrument continues the normal measurement.



Fig.37 Current simulation

Table21 Details for Current simulation

	LM78X0	LM78X1	LM78X2
Parameter name	Current simulation		
Parameter range (ma)	4 ~ 20		
Default (ma)	4		
Related parameters	Null		
Option meaning	Check the current output manually.		
Special matters	Null		

6.5.4.10. [False Echo]



Fig.38 False Echo

[False Echo] is used to form a specific TVT for the current environment with known obstructions or interference, and together with [False echo area] and [False echo mode]. It suppresses the unwanted echoes wherever it appears. Ideally the vessel should be empty or almost empty and thus all the potential false echoes would be learned. And if there is an agitator, it should be running. Example of False Echo Learning is shown in Fig.39.

Example before Auto False Echo Suppression

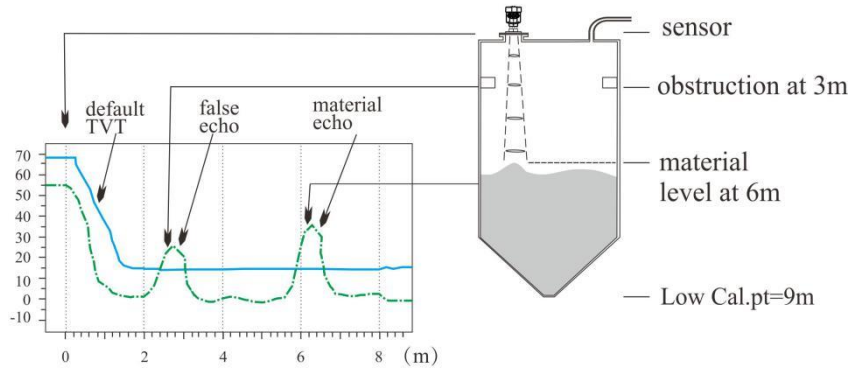

Example after Auto False Echo Suppression

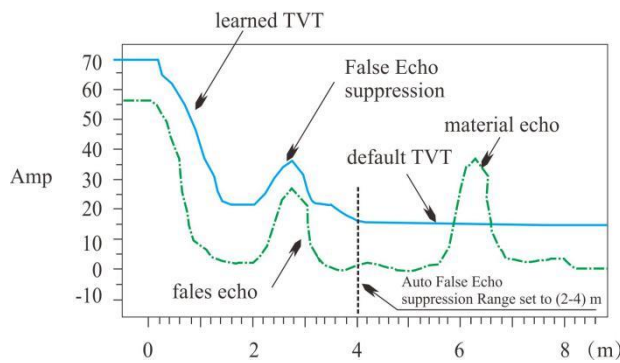

Fig.39 Example of False Echo Learning

Note: A Time Varying Threshold (TVT) hovers above the echo profile to screen out unwanted reflections (false echoes). In most cases the material echo is the only one which rises above the default TVT.

6.5.4.11. [False echo range]

False Echo Rang specifies the region within which the TVT is learned. It is invalid if the [False echo mode] is “full range”, which means the TVT is learned from [near range] to [far range]. The range need to be set carefully to avoid the material echo being screened out.



Fig.40 False echo range

Table22 Details for False echo range

	LM78X0	LM78X1	LM78X2
--	--------	--------	--------

Parameter name	False echo rang
Parameter range (m)	Start: 0 ~ far range End: (near range + 0.1m) ~ far range
Default value (m)	0
Related parameters	Null
Option meaning	Set range for false echo learning
Special matters	Null

6.5.4.12. [False Echo Mode]

[False echo mode] specifies the mode of false echo learning.



Fig.41 False Echo Mode

Assuming that the start of the false echo area is 2m and the end is 4m as shown in Fig.39, the meaning of the different option combinations is as follows:

Table23 Details for False echo mode

	Full range*	include region	Exclude region
New	false echo is learned from [near range] to [far range]	False echo is learned within 2m ~ 4m and the rest remains the same.	False echo is learned within full range exclude 2~4m and the rest remains the same.
Clear	Clear false echoes learned from [near range] to [far range]	Clear the false echo within 2m ~ 4m and the rest remains the same.	False echo is cleared within full range exclude 2m~4m, the rest remains the same.

6.5.4.13. [Fill rate]

[Fill rate] is used to adjust the response rate of the level meter to the increases of the actual material level. [Fill rate] need to be set according to the actual situation, or the default setting would be applied as in Section 6.5.1.1.



Fig.42 Fill rate

6.5.4.14. [Empty rate]

[Empty rate] is used to adjust the response rate of the level meter to the decrease of the actual material level. [Empty rate] need to be set according to the actual situation, or the default setting is applied as in Section 6.5.1.1.

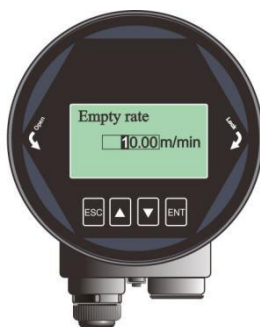

Fig.43 Empty rate

Table24 Details for False Fill/Empty rate

	LM78X0	LM78X1	LM78X2
Parameter name	Fill/Empty rate		
Parameter range (m / min)	0~300		
Default value (m / min)	0.1		
Related parameters	Null		
Option meaning	Set the response rate for material tracking		
Special matters	Only work in tracking mode		

6.5.4.15. [Fail-safe mode]

[Fail-safe mode] is used to set the output current when the level meter encounters a fault together with [Fail-safe Timer]. The “Keep” option indicates the last valid measured current would be output. Detailed error code refers to **Error Code**.



Fig.44 Fail-safe mode

6.5.4.16. [Fail-safe Timer]

It is also known as lost of echo timer (LOE timer). Fail-safe mode would be turned on when [Fail-safe Timer] expires. The default value is 100s and the range is 0-1000s.



Fig.45 Fail-safe Timer

6. 5. 5 Information

Information contains four items: [Lcd version], [Device version], [Model], [Serial NO.]and [Tag]. [Lcd version] and [Device version] carry the information of the software and hardware that the instrument is running on.



Fig.46 Lcd and Device Version

[Model] shows the product model.



Fig.47 Sensor model

[Serial NO.] shows the product Serial Number



Fig.47 Serial NO.

[Tag] is used to set the unique identification for each instrument. It contains 16 characters and each character can be set to '0' ~ '9' or 'a' to 'z'.



Fig.48 Tag

6. 6 Keyboard input method

This section is to introduce the method of inputting digital number for setup in [Input Interface],

(1) Press [DN] to shift the cursor to the right.



Fig.49 Shift the cursor

(2) Press [UP] to cycle from 0 to 9.



Fig.50 Cycle from 0 to 9

(3) Press [ENT] to complete the setting and "OK" will be displayed in the lower right corner of the LCD for 1 second, which means setting is accomplished.



Fig.51 Successful setting

7. Menu tree

7.1 First-level menu tree

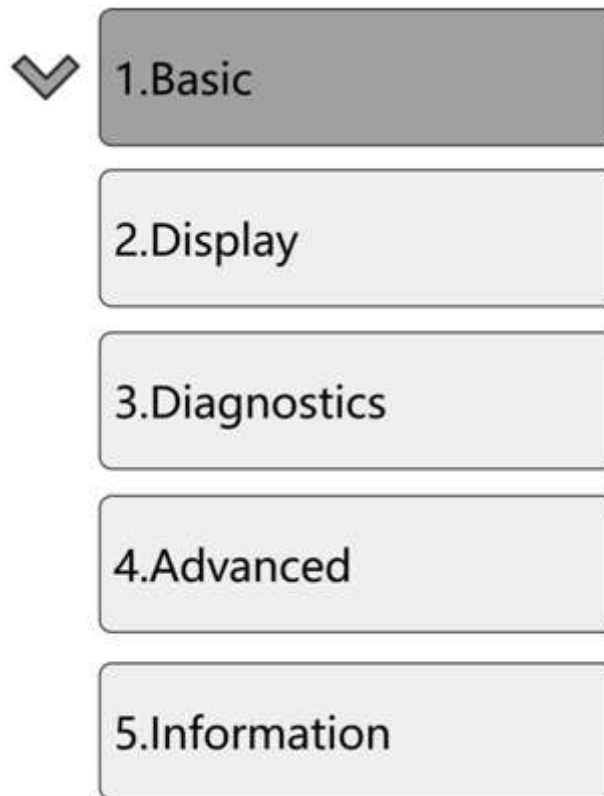

7.2 Secondary menu tree-basic settings

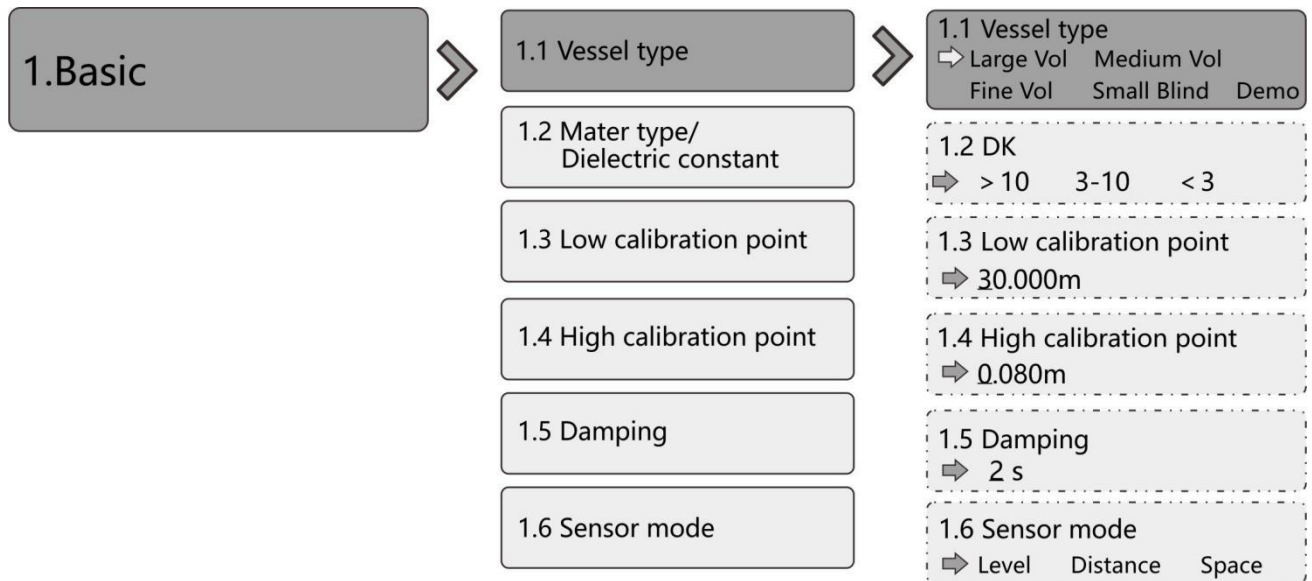

7.3 Secondary menu tree-display

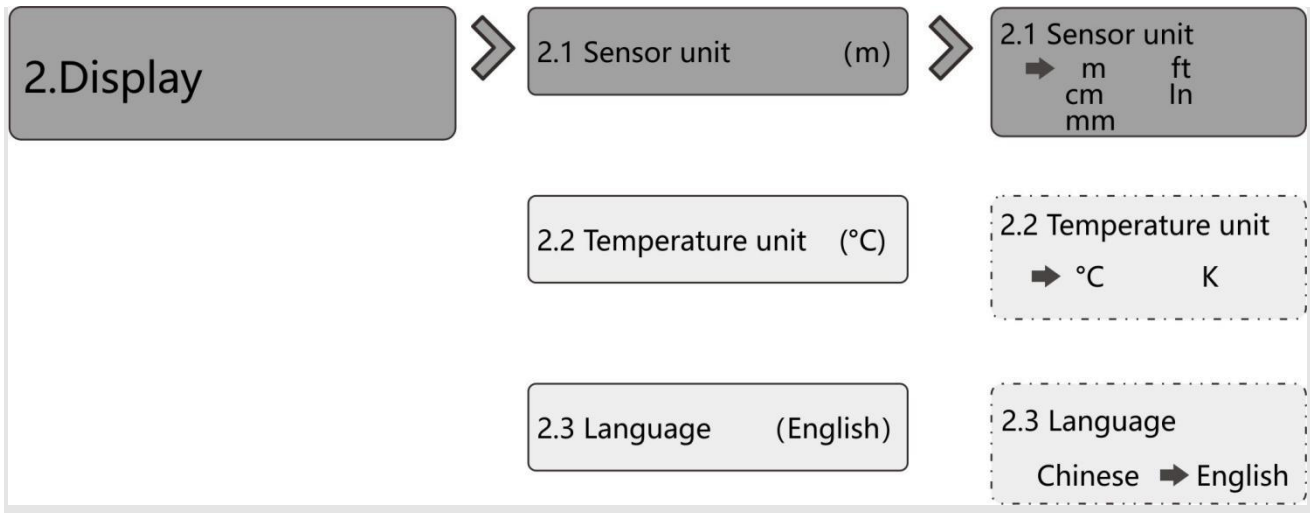

7.4 Secondary menu tree-diagnostics

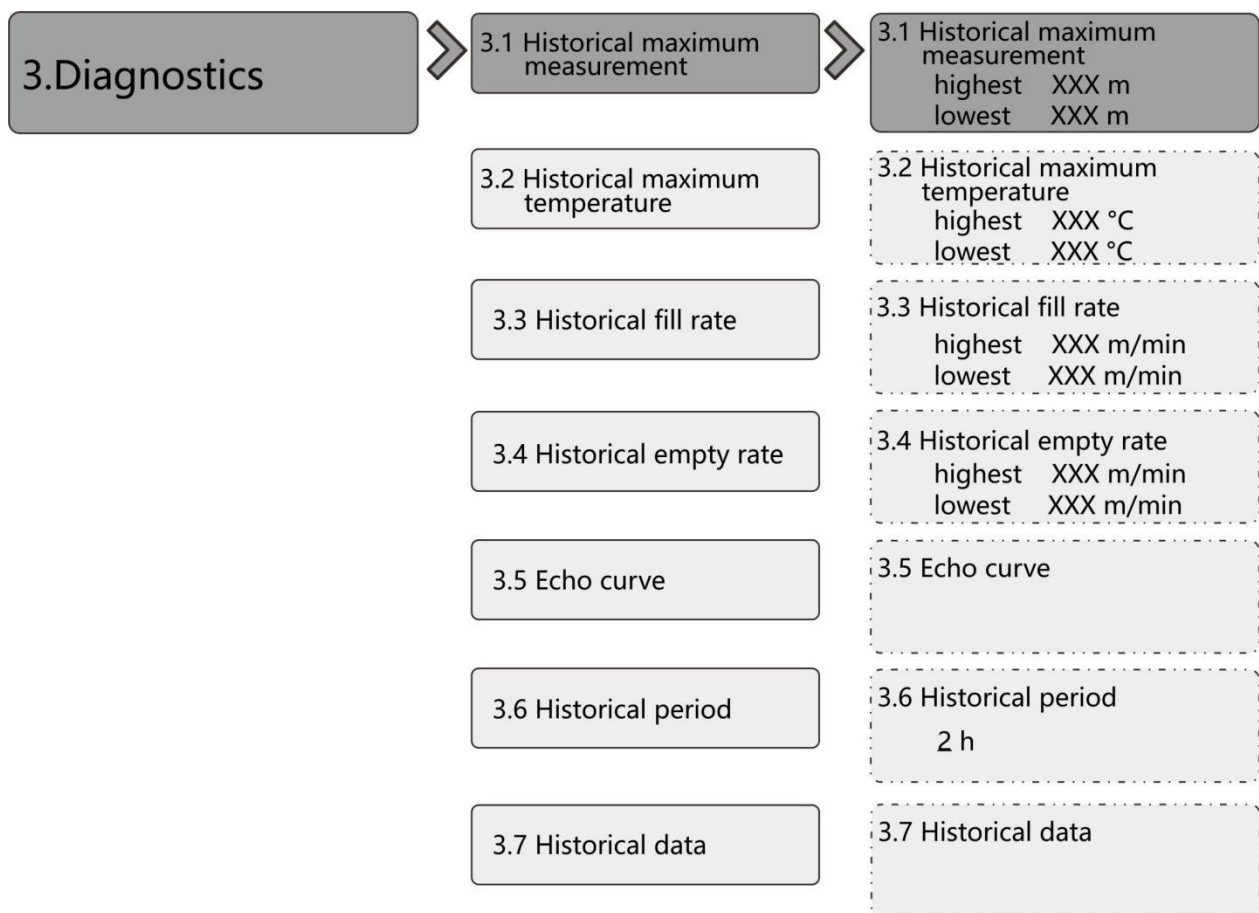

7.5 Secondary menu tree-Advanced

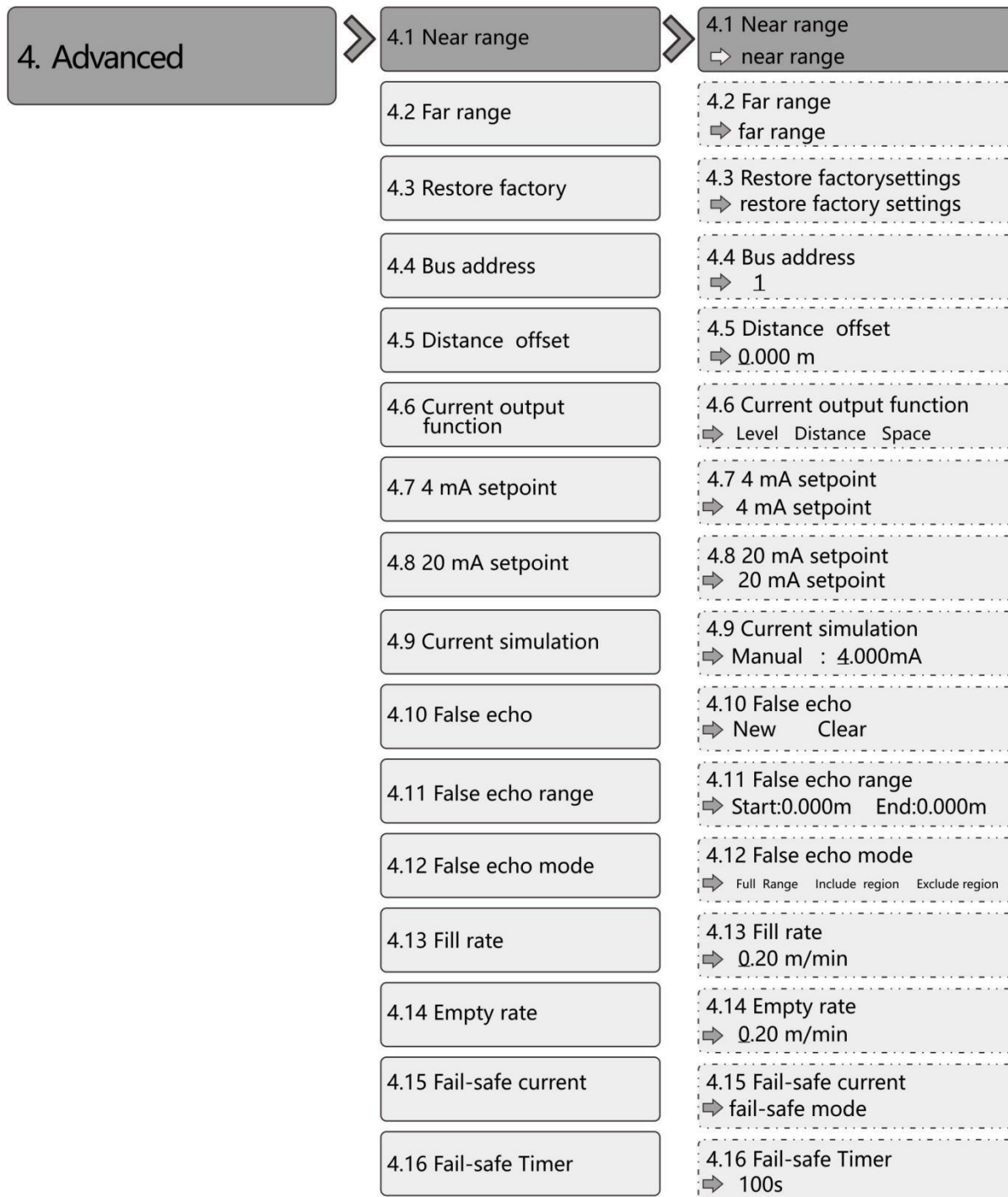

7.6 Secondary menu tree-information

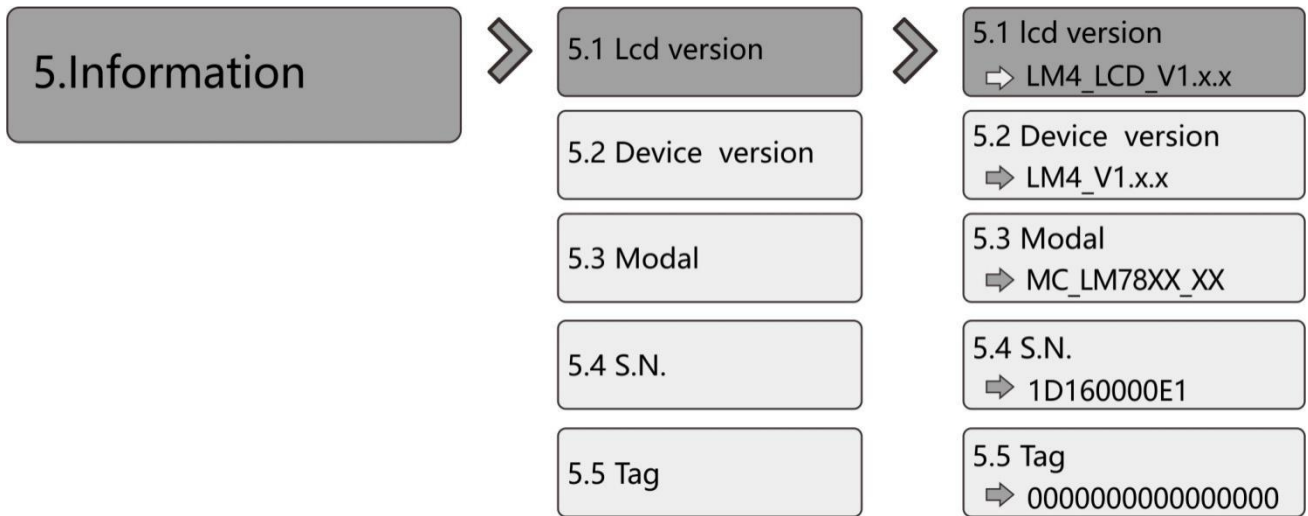

8. Problem Diagnosis

Phenomenon	Possible reason	Actions

9. Software Version History

Lower computer version	Release date	Update description
LM2_V1.1.27	20200214	
LM2_V1.1.49	20200501	

Display version	Release date	Update description
LM4_LCD_V1.1.27	20200214	
LM2_LCD_V1.1.42	20200504	

10. Error Code

Error code is displayed in the Measurement Interface as shown below



Fig.52 Error code

Table25 Details for Error code

Index	Binary	Hex	Meaning
1	0000 0000 0000 0000	0000	Work regular
2	0000 0000 0000 0001	0001	Lost echo
3	0000 0000 0000 0010	0002	Communication err with TR
4	0000 0000 0000 0100	0004	No Factory False echo study
5	0000 0000 0000 1000	0008	4-20ma error
6	0000 0000 0001 0000	0010	Current manual output
7	0000 0000 0010 0000	0020	LCD Communication error
8	0000 0000 0100 0000	0040	Connection err with TR
9	0000 0000 1000 0000	0080	MCU Hard fault
10	0000 0001 0000 0000	0100	MCU Hard fault
11	0000 0010 0000 0000	0200	Temperature sensor error
12	0000 0100 0000 0000	0400	MCU Hard fault

11. Glossary

Beam Angle: Half power beamwidth. Lm78xx has 3°beamwidth and the divergence of the beam is only ±2.6m at a distance of 100m.

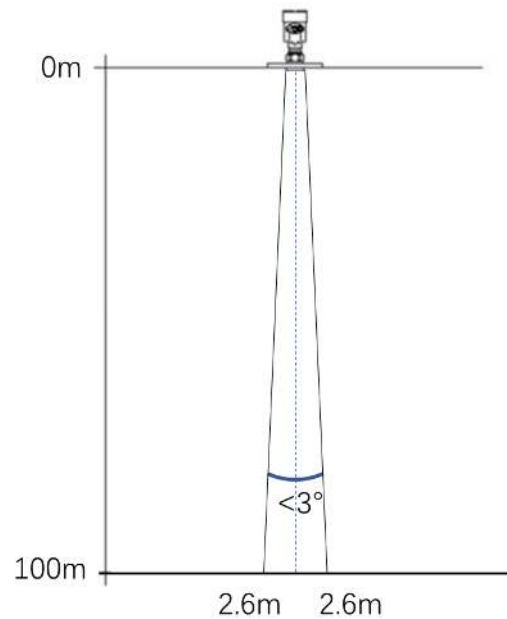

Fig.53 Beam spread

Range resolution: It refers to the minimum distance that two objects can be distinguished by the level radar. LM78xx has a 5.1GHz bandwidth, and thus the ideal **Range resolution**= $C/2B \approx 3\text{cm}$.

Measurement Accuracy: The minimum shift that can be distinguished by the level radar. LM78xx's echo signal is analyzed by unique algorithm, and the accuracy is 0.5mm.

Ambient temperature: The temperature of the surrounding air that comes in contact with the equipment.

Blind zone: the limitation of the level meter, that is to say, the radar cannot give the right measured result within Blind zone.

dB (decibel): A unit representing the amplitude of a signal.

Dielectric constant (DK): The ability of a dielectric to store electrical energy. The increase in dielectric constant is directly proportional to the increase in reflection amplitude. The dielectric constant of air is 1.

Echo: A reflected signal with amplitude large enough to be distinguished from the transmitted signal by a certain method is called an echo.

False echo: Echoes that are not the one of the real target. Generally speaking, false echoes are generated by obstacles in the container.

Multiple echoes: Multiple echoes due to multiple reflections between the radar and the target

Polarization: The properties of the emitted electromagnetic waves, describing the direction and amplitude of the electric field vector changes over time.

Repeatability: The variance of multiple measurements of the same variable in the same situation.

Speed of light: The speed of electromagnetic waves in free space is 299,792,458 meters per second.